

CAT 5 AGAP Systems

With Easymat & IDROMAT Control

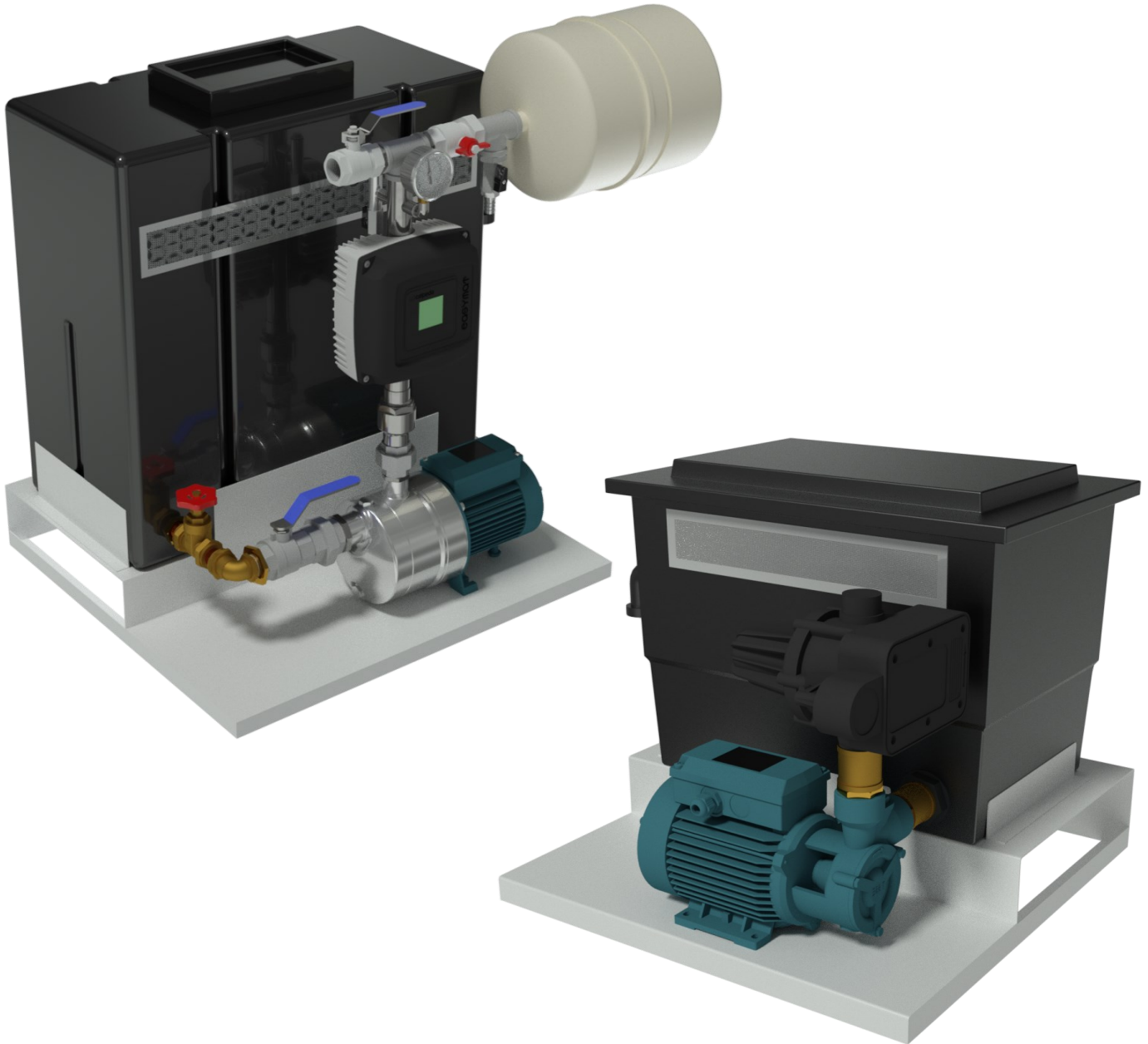

AGAP SETS

General:

A range of economically priced, fixed or variable speed AGAP sets with 18 and 80 litre nominal capacity tanks. Options for the sets to feature the Easymat variable speed controller or our IDROMAT flow controller.

Pumps:

MXH Series: Stainless steel, horizontal, multistage centrifugal pumps. WRAS Approved.

BT Series: Bronze / brass, peripheral pumps.

Operating Conditions:

Fluid:	Clean cold water
Fluid temp.:	Max 25°C
Air ambient temp.:	Max 40°C
Max pressure:	10 Bar operational
Control:	Easymat variable speed control or IDROMAT fixed speed flow controller
Rated:	Continuous service

FEATURES

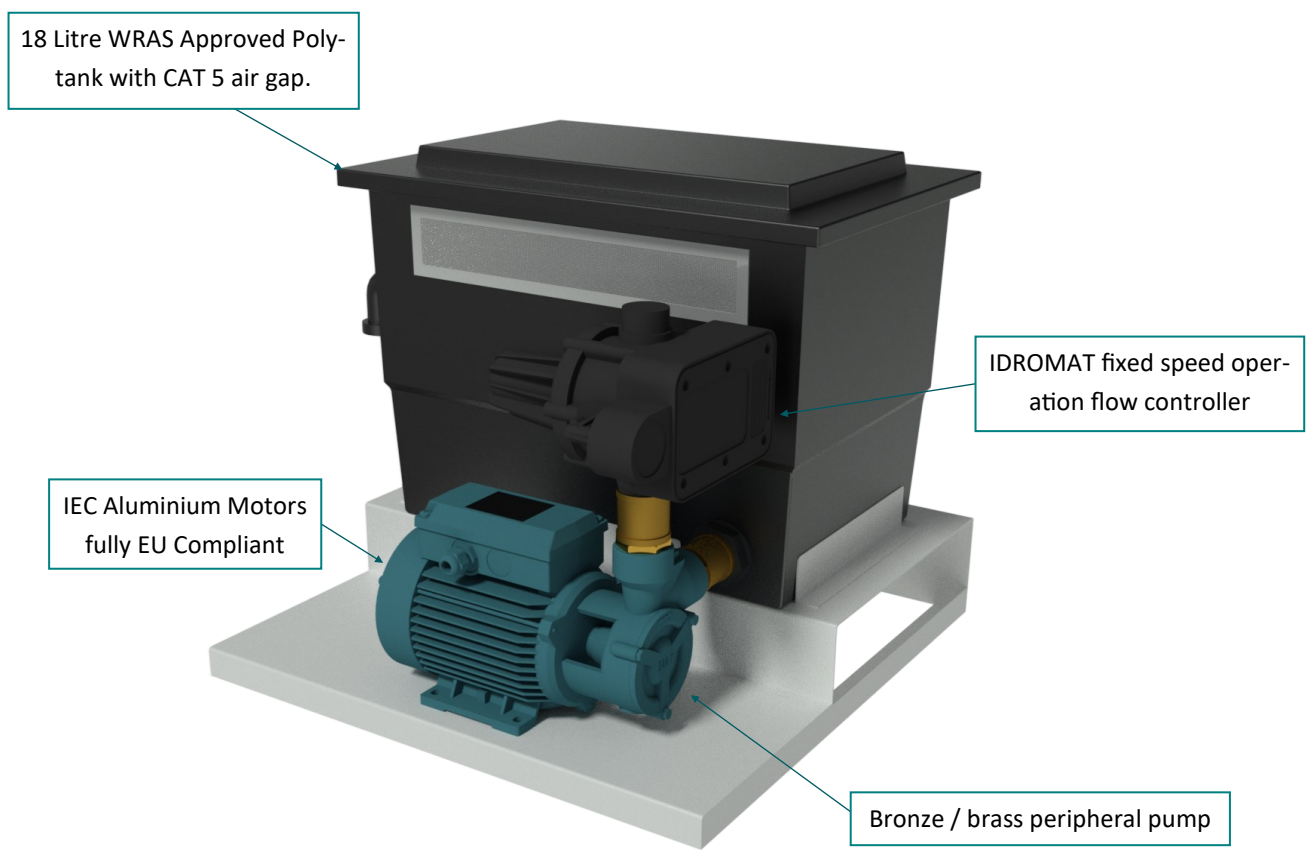
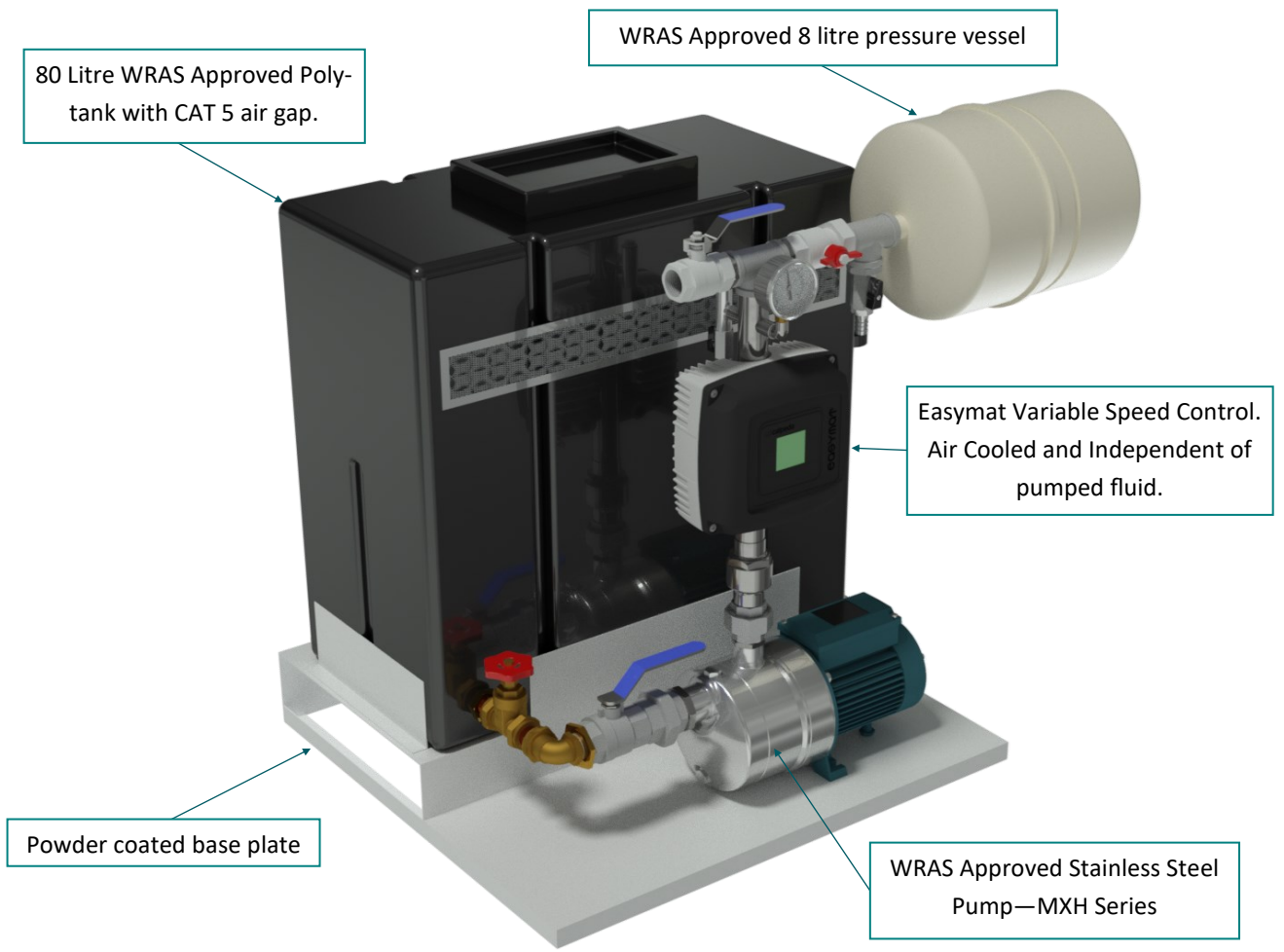

EASYMAT CONTROL

Control Panel

The Easymat is equipped with a control panel for simple system programming and parameter monitoring.

The 2 scroll buttons are used to scroll through the different operating parameters the Easymat can display.

At the same time you can use the 2 scroll buttons to move around the set up menu and to change the various options.

The custom LCD display gives a clear overview of the system condition and operating parameters. The icons above and below the display confirm the mode in which the Easymat is working and highlight any problems.

The 4 set-up buttons allow the operator to move between the set-up menus and to start and stop the pump/s. The symbols are designed to make the various function of each button clear. With these 4 buttons and the two scroll buttons you can manage all the set-up and operating parameters without the use of an external controller or computer.



LCD Display

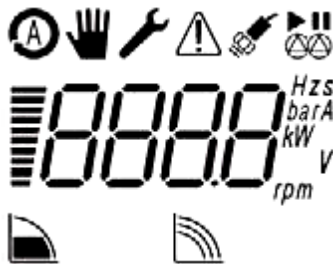

The integrated LCD custom display gives you an easy overview of the system condition and operating parameters.



Display Area. The display area shows the status of the parameters of the pump.

The **Operating Icons** show in which mode the system is operating.



Constant pressure mode.

The system keeps the pressure constant as the demand for water changes. The user can choose the operating pressure as required.



Fixed speed mode.

The system works at a fixed speed which can be determined by the user as required.

The **System Icons** show in which way the system is operating.



Auto mode.

The icon shows that the system is operating in auto mode (constant pressure). The constant pressure icon will be shown on the lower section of the display.



Manual mode.

The icon shows that the system is operating in manual mode (fixed speed). With the navigation buttons the user can change the speed. The fixed speed icon will be shown on the lower section of the display.



Set-up mode.

The icon shows that the set-up menu is activated, in this mode it is possible to change all the operating parameters of the Easymat. Using the navigation buttons it is possible to scroll through the parameters and change them as required.



Sensor state.

This indicates the state of the pressure transducer connected to the Easymat. When lit it indicates that the transducer is working correctly, if flashing it indicates a transducer fault or incorrect connection.



Alarm.

indicates that there is a fault on the system. A corresponding error number will be shown on the display.

This

IDROMAT CONTROL

Description

Construction

Regulation device for pump control equipped with flow and pressure sensor connected to an electronic system.

Inlet and delivery connection ports of the same diameter (G1).

Built-in check valve.

Pressure gauge 0-12 bar supplied as standard for all the models.

Automatic reset function for the reset of the system without manual operation.

Applications

Automatic control of pumps for water supply and increase of network pressure.

Control of starting/stopping of the pump when cocks are opened/closed.

For protection of the pump:

- against dry running;
- against the risk of operation without water at the inlet (caused by a lack of water inflow in the inlet pipe under positive suction head, by a non-immersed suction pipe, by excessive suction lift or by air entering the suction pipe);
- against operation with closed connection ports.



Control Panel



Status indications and system reset

The three LEDs give the information about the system operativity, the first LED indicates the presence of supply, the second LED indicates if the pump is operating and the third LED indicates if an alarm has occurred in the system. The Reset button allows to manually restart the system when an alarm occurs.

Features

Flexibility

The standard double supply voltage (only for Idromat 5) allows to connect power supply of 115V or 230V without modifications on the device.

Easy to use

With the Idromat 5e it is possible to change the re-start pressure, the operation is possible also with the pump that operate.

Safety

The device includes a automatic re-start system with anti-lock mode in order to reduce the user operations.

Reliability

The pressure gauge locking system (patented) allows an easy replacement in case of failure and an easy drainage of the device.

User Friendly

The high luminosity LEDs allows a higher visibility of the operating conditions.

MXH SERIES

Performance Data

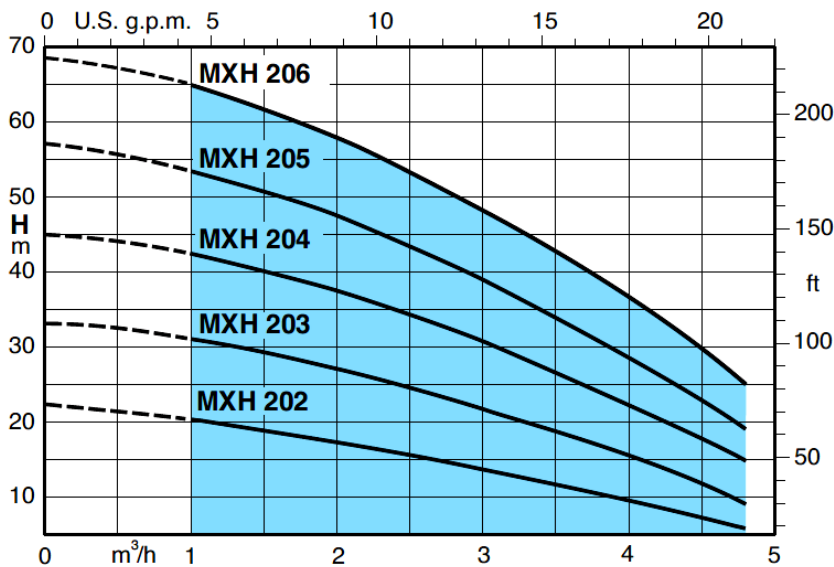

Approval No: 1906314

1 ~	230 V	P ₁		P ₂		Q	m ³ /h									
		A	kW	kW	HP		0	1	1,5	2	2,5	3	3,5	4	4,25	4,8
							0	16,6	25	33,3	41,6	50	58,3	66,6	70,8	80
MXHM 202E	2,3	0,5	0,33	0,45	H m	22	20	18,5	17	15,3	13,4	11,4	9,3	8,2	5,6	
MXHM 203E	3	0,65	0,45	0,6		33	31	29	27	24,5	21,7	18,6	15,5	13,8	9	
MXHM 204/A	4,2	0,9	0,55	0,75		45	42,5	40,4	37,5	34,5	30,8	26,7	22,4	20,1	14,8	
MXHM 205/A	5,4	1,2	0,75	1		57	53,5	50,5	47,5	43,5	39	34	28,5	25,8	19	
MXHM 206	7,4	1,5	1,1	1,5		68,5	65	61,5	58	53,5	48	43	36,5	33,5	25	

Materials

Constructed fully of stainless steel fitted with carbon/ceramic/EPDM mechanical seal.

Motor

Capacitor inside the terminal box.

Insulation class F. Protection IP 54.

Motor suitable for operation with frequency converter from 1,8 kW.

Classification scheme IE3 for three-phase motors from 0,75 kW.

Features

Extra safety

Against running dry, with the suction port above pump axis.

Reliable

All hydraulic parts in contact with the pumped liquid are of stainless steel.

For liquids from -15 °C to 110 °C.

Robust

Single-piece, thick barrel casing.

Compact

Single-piece lantern bracket and base without protruding flange.

Greater protection

Against leakage, with the pump casing cover separated from the motor shield.

Possibility of inspecting the seal through the side apertures between the two walls.

Greater protection against water entering the motor from outside provided by an extension of the pump casing around the lantern bracket.

T SERIES

Performance Data

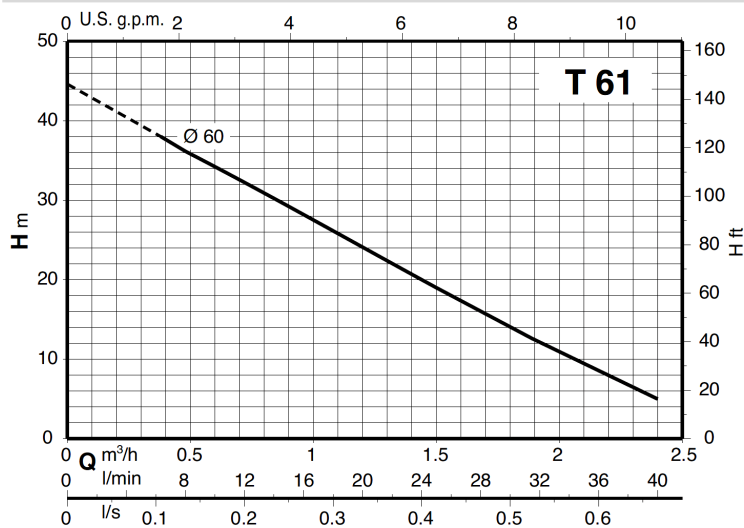

1 ~	230V P ₁		P ₂	
	A	kW	kW	HP
B-TM 61E	2,5	0,55	0,33	0,45

Q	0,06	0,12	0,24	0,38	0,48	0,6	0,75	1	1,2	1,5	1,89	2,4	3
m ³ /h													
l/min	1	2	4	6,3	8	10	12,5	16	20	25	31,5	40	50
				38	36	34	31,5	28	24	19	12,5	5	

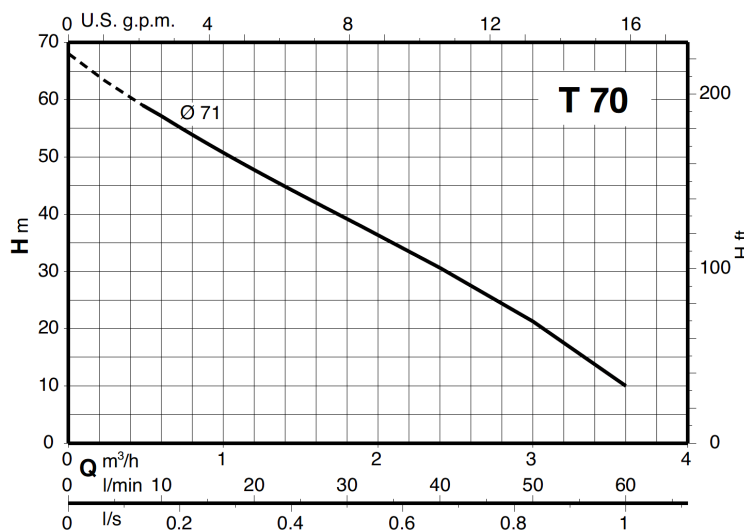

1 ~	230V P ₁		P ₂	
	A	kW	kW	HP
B-TM 70/A	6	1,3	0,75	1

Q	0,06	0,12	0,24	0,38	0,48	0,6	0,75	1	1,2	1,5	1,89	2,4	3	3,6	4,2
m ³ /h															
l/min	1	2	4	6,3	8	10	12,5	16	20	25	31,5	40	50	60	70
					59	57	55	51	48	43	38	30	22	10	

Materials

Constructed from bronze / brass and fitted with carbon/ceramic/NBR mechanical seal.

Motor

Capacitor inside the terminal box.

Insulation class F. Protection IP 54.

Classification scheme IE3 for three-phase motors from 0,75 kW.

Constructed in accordance with: EN 60034-1; EN 60034-30, EN 60335-1, EN 60335-2-41.

Features

Range

The number of pumps in the range can meet a range of services required by the user.

Optimised hydraulics

The pump hydraulics are designed to ensure high performance and consistency of performance.

Reliable

The bearing and shaft are designed to ensure the reduction of the stress, providing high reliability under all operating conditions.

DIMENSIONS

BTM61E-AGAP18

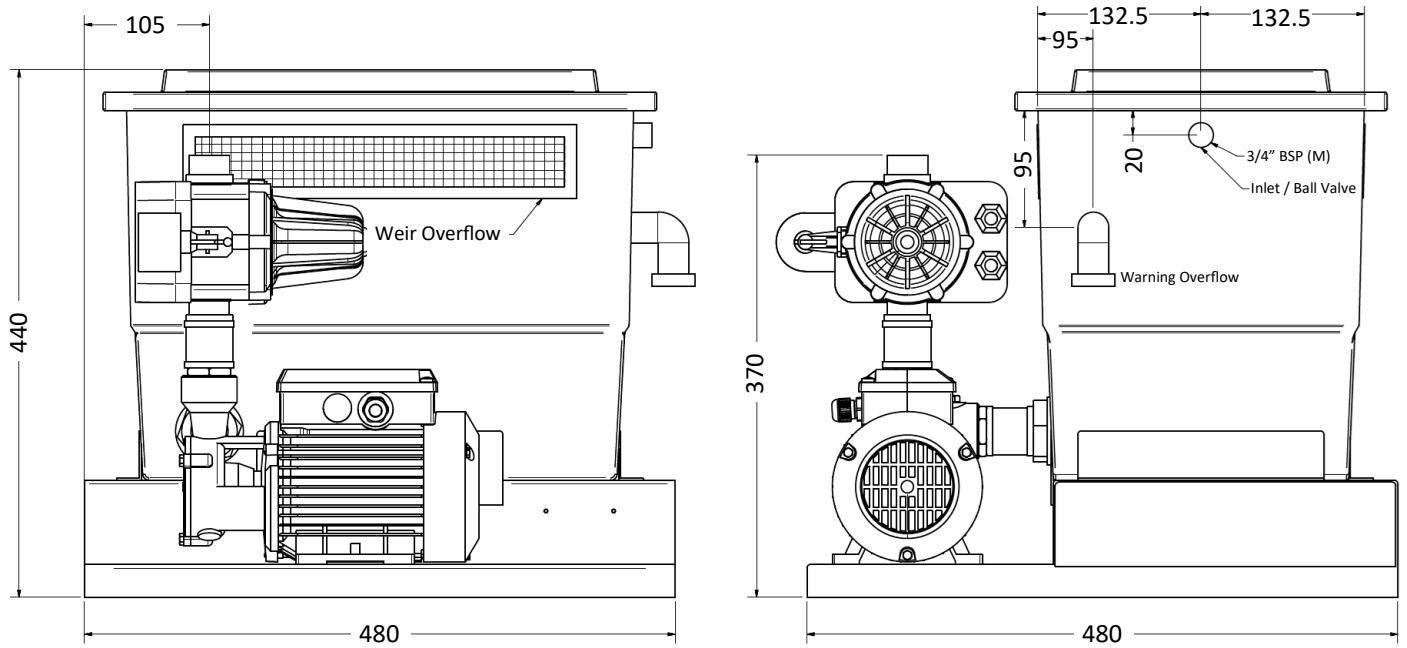

BTM61E-AGAP80

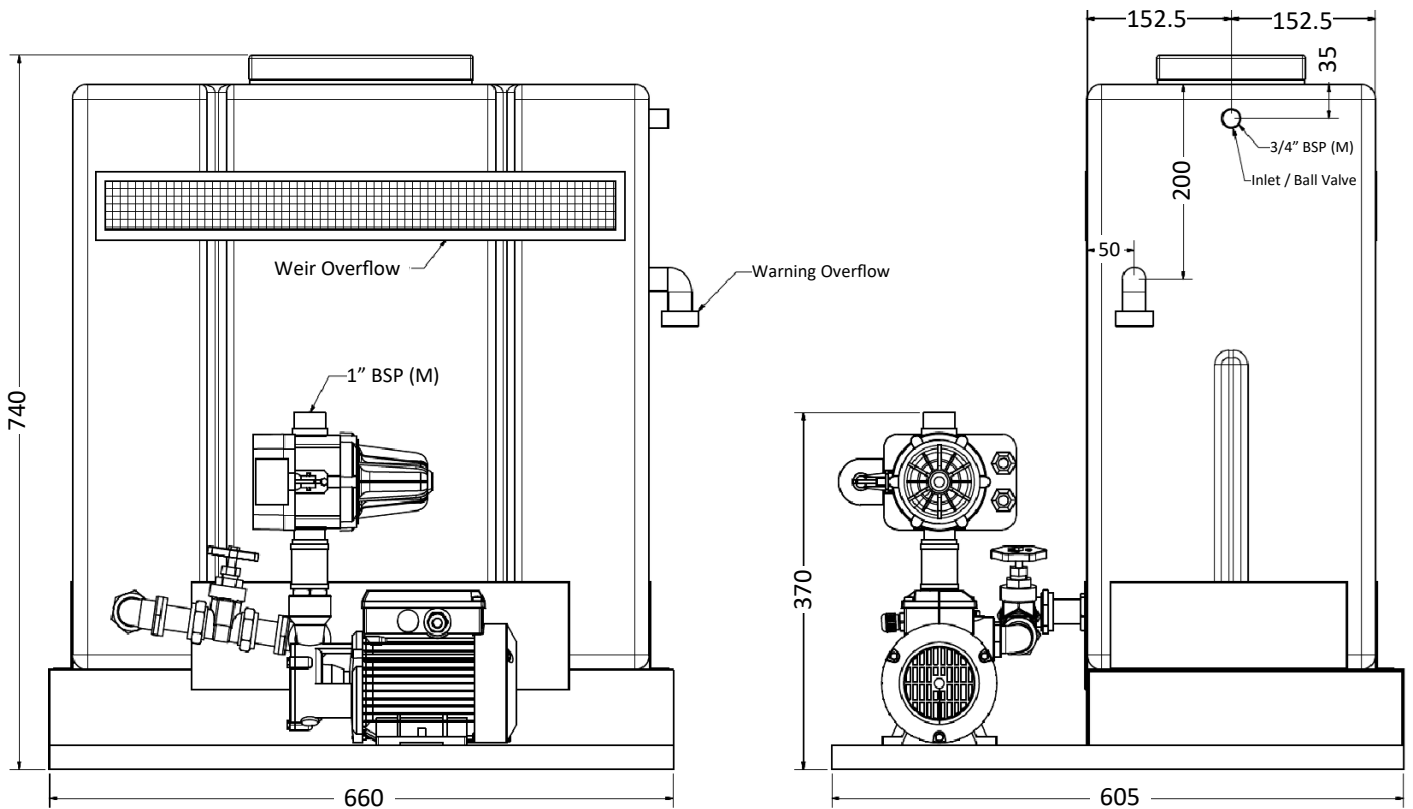

DIMENSIONS (continued)

BTM70/A-AGAP80

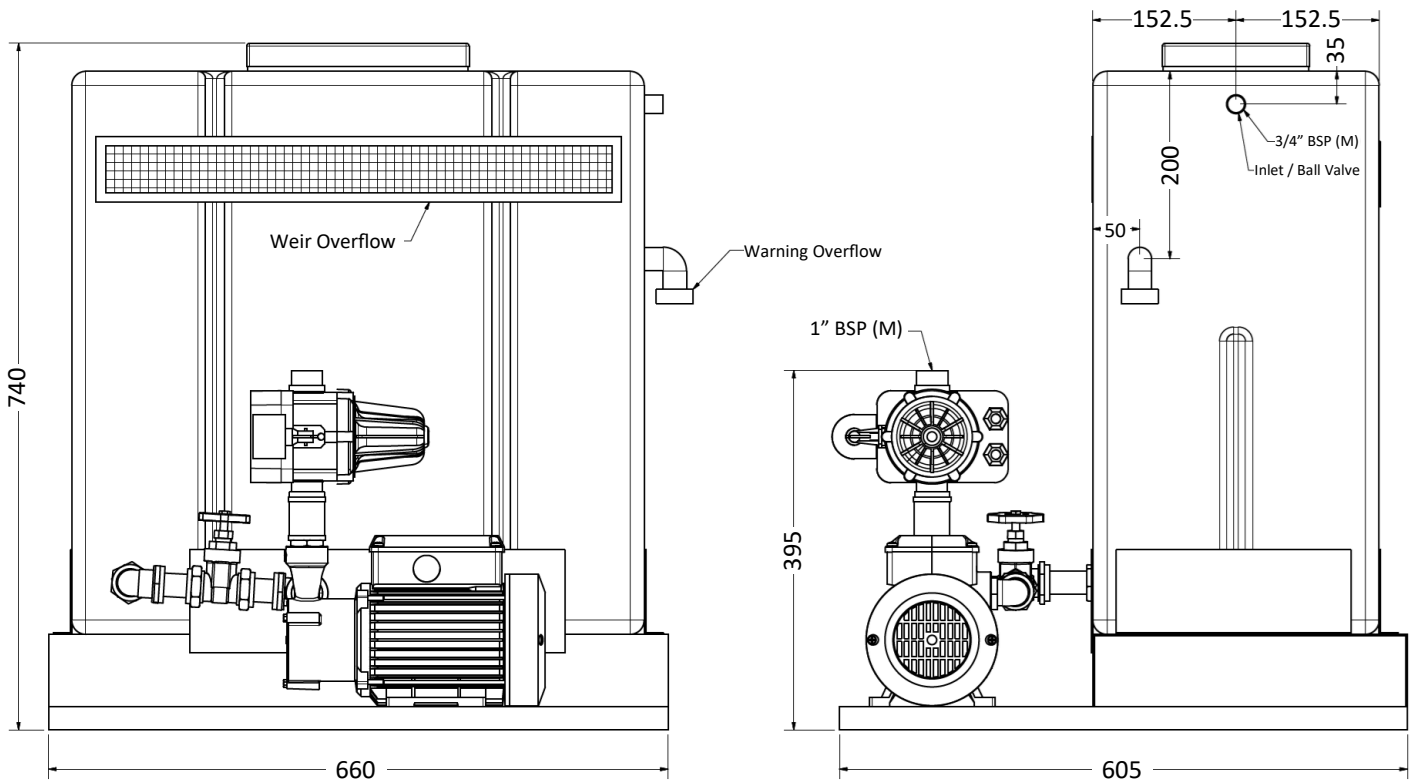

MXHM20...-AGAP80

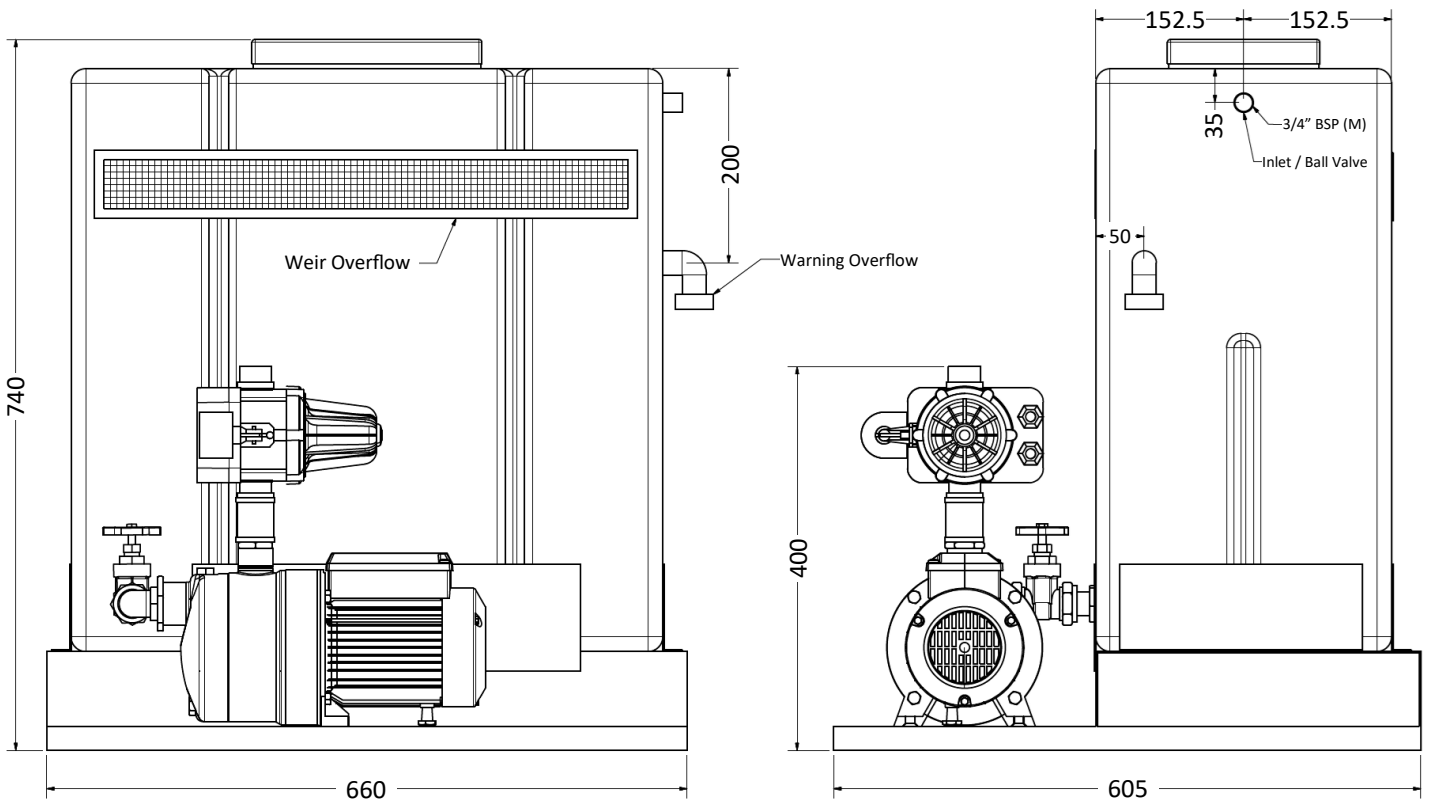

DIMENSIONS *(continued)*

1MXH20...-EMT-8-AGAP80

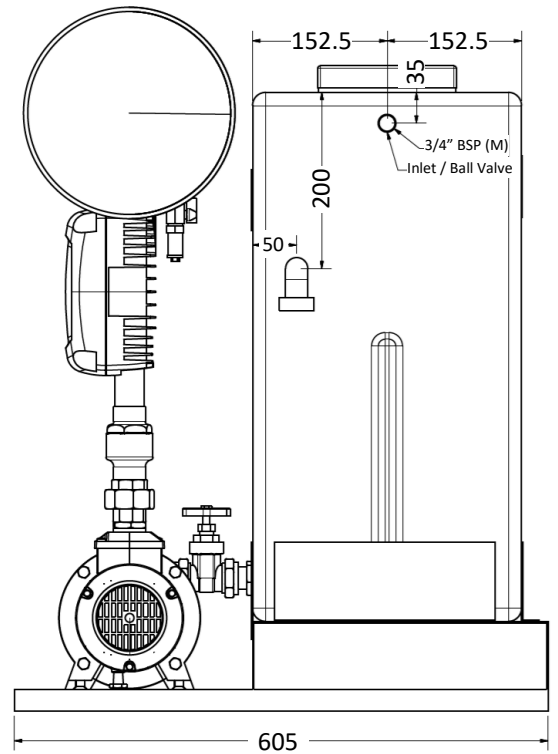
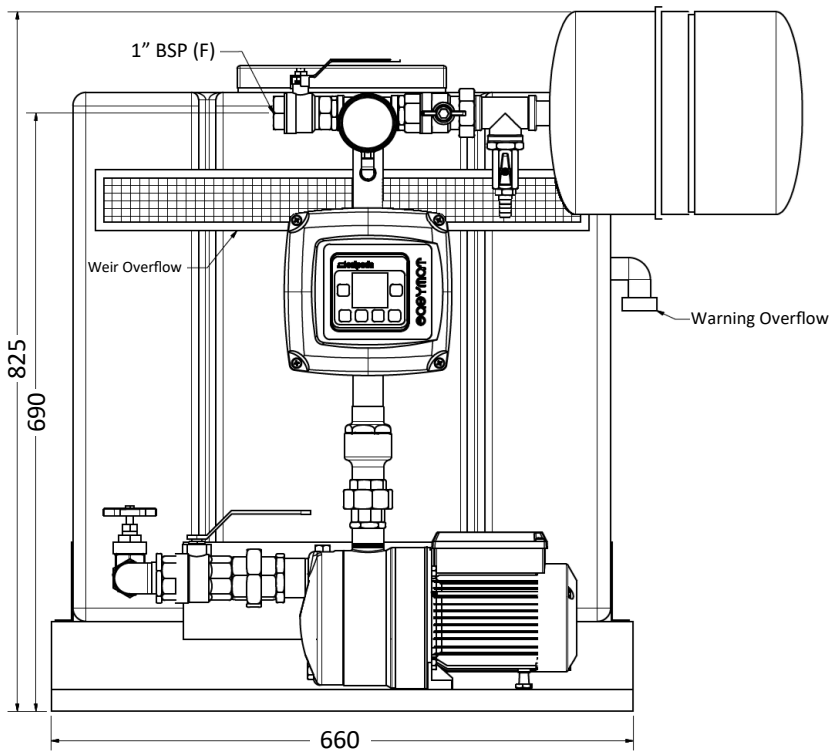

Notes

